

# Installation Manual

## Sub1 Toe Kick Accessory

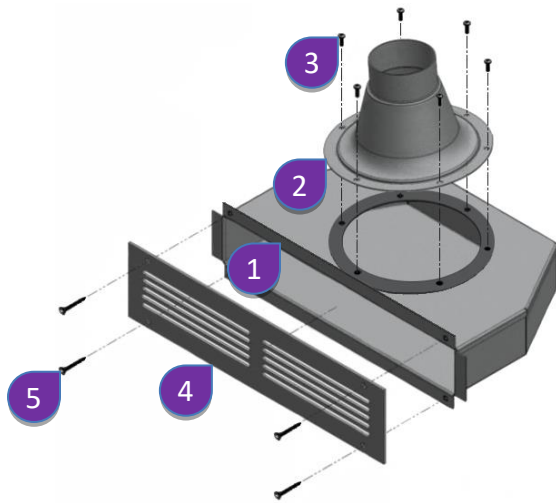

Cutout Dimension:	2.6" H x 14.63" W 66mm H x 372mm W
Flange Dimension:	3.95" H x 15.9" W x 0.065" D 100mm H x 404mm W x 1.65mm
Rear Assembly Dimension:	7.23" H x 9.08" 14.62" W 184mm x 231mm x 372mm Not including SUB1 Port Tube
Minimum Depth Required:	9.08" (231mm) Does not include the Sub1
Minimum Height Required:	13.00" (330mm) Includes height for SUB1 Port Tube attachment and grille
Typical Wall Thickness	5/8" (16mm), Max 7/8" (22mm)
Grille Mounting Pattern	13.5" x 3.25" 343mm x 82.5mm

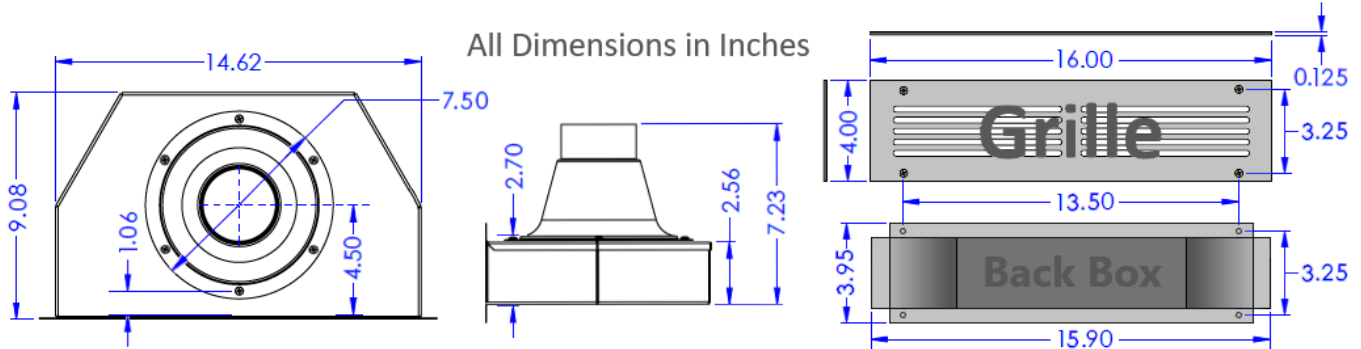

The below instructions are for interior cabinet installation where access is available. Use these instructions along with the Sub1 manual to guide your custom installation. Some additional hardware is required. Plan your installation before you begin. Consult with the necessary subcontractors. NOTE: The toe kick is installed in the same way as an HVAC toe kick.

1. Cut an opening in the toe kick of the cabinet to fit the **toe kick back-box** (1). The toe kick can pass through the front of the opening or be rear mounted. When front mounting, the maximum material thickness that it can pass through, and still allow attachment of the **transition cone** (2) is 7/8" (22mm). If the material thickness is greater than 5/8" (16mm), the height of opening must be 2.75" for clearance of the flange on the transition cone.
2. If required cut a hole at the proper location for the transition cone, (8" diameter typical).
3. Slide the back-box into the rectangular opening of the cabinet toe kick or rough-in.
4. Using appropriate hardware for the installation, attach the back-box flange to the cabinet, (front or rear). The back-box may be mounted to an unfinished or rough-in surface, with the finished surface added later. The finish layer must be cut to allow maximal air flow and prevent obstruction of the exit.
5. Using the six **8-32 machine screws** (3), attach the transition cone to the toe kick back-box. Ensure the gasket makes a good seal around the flange and tighten by hand.
6. Attach the Grille:
  - a. If using the included **grille** (4), use **four black #8 flathead screws** (5) (not included). Align the mounting holes of the grille to the flange on the toe kick back-box and screw through the grille and flange into the face of the cabinet toe kick. This will clamp the grille and back-box to the cabinetry.
  - b. If using a custom grille, the back-box screw mounting can be used, or the 4 corners of the back-box allow for the grille to screw directly to the face of the toe kick trim. Alternatively, a custom grille can be screwed into the back-box mounting locations or can be attached directly to the finish surface trim. Consult with the carpenter or HVAC installer.
7. Attach the Port Tube from the SUB1 (included with the SUB1) and install the SUB1 as normal. See Sub1 Manual.



*WISDOM and the stylized W are registered trademarks of Wisdom Audio.*

Wisdom Audio 1572 College Parkway, Suite 164  
Carson City, Nevada 89706 USA  
TEL (775) 887-8850  
FAX (775) 887-8820  
wisdomaudio.com